

Reduction Tubes Ordering Form

Customer _____

Lathe brand / model _____

Clamping system model / type _____

spindle internal \varnothing _____

spindle Length _____

Important

Maximum internal \varnothing of the reduction tube is 6 mm < spindle max \varnothing

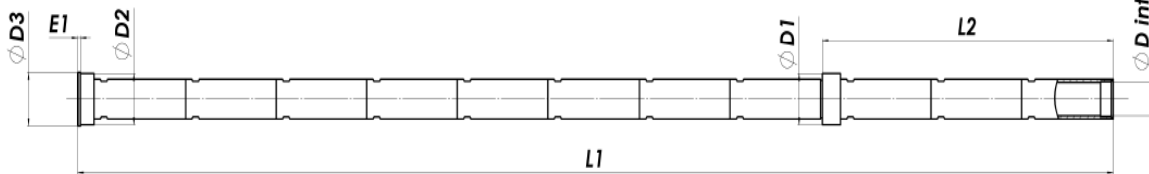

internal \varnothing of reduction tube (D int.) Even numbers only _____

Front ring \varnothing (D1) _____

Rear ring \varnothing (D2) _____

Retaining \varnothing (D3) _____

Retaining thickness (E1) _____

Total length of spindle reduction (L1) _____

Front ring position (L2) _____

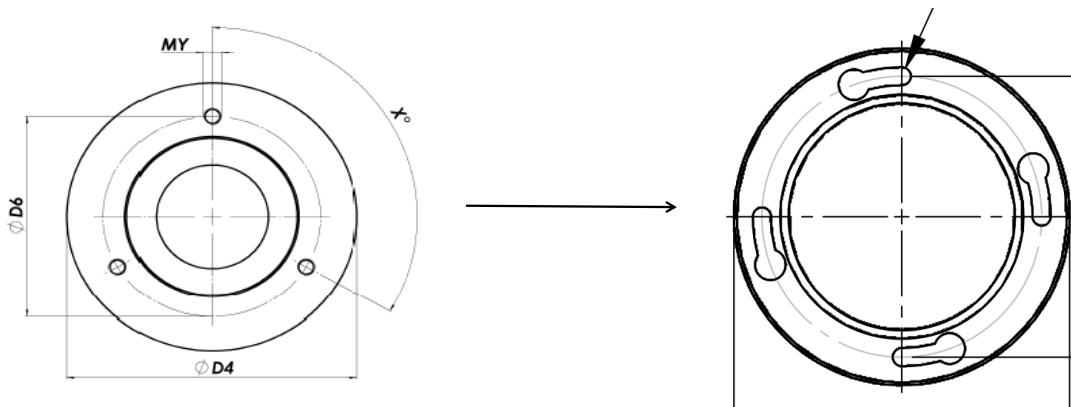

Flange outside \varnothing (D4) _____

Pitch \varnothing (D6) _____

Qty, angle & \varnothing of thread \varnothing (MY) _____